

# PRAMAM

## VALVE MANIFOLDS

---



Catalogue No. VM-1  
June 2003.

## 2-3-5 VALVE MANIFOLDS

**PANAM** range of Valve Manifolds offer a safe and economical method of installation to control and measure pressure of liquids and gaseous media. They are ruggedly manufactured and precision machined to the most exacting dimensional tolerance to ensure perfect installation and application

**PANAM** Valve Manifolds are functionally installed to control, measure , isolate , equalize , calibrate, drain, vent or differentiate the pressure of liquids and gases.

**PANAM** Valve manifolds series offer 2, 3 and 5 valves configurations which come in remote mounting "R" Type ( Pipe to Pipe ), direct mounting "T" & "H" type (Pipe to Flange & Flange to Flange ) onto the instrument on 2-1/8" (54mm) centre.

## Contents

Material of Construction		1
Pressure vs. Temperature		2
2 Valve Manifold-Pipe to Pipe	2VM-SS-8-R	3
2 Valve Manifold-Pipe to Flange	2VM-SS-8-T	4
2 Valve Manifold-Flange to Flange	2VM-SS-8-H	5
2 Valve Manifold Remote Mount	2VM-SS-8-RM	6
2 Valve Manifold Direct Mount	2VM-SS-8-DM	7
3 Valve Manifold-Pipe to Pipe	3VM-SS-8-R	8
3 Valve Manifold-Pipe to Flange	3VM-SS-8-T	9
3 Valve Manifold-Flange to Flange	3VM-SS-8-H	10
3 Valve Manifold Direct Mount	3VM-SS-8-DM	11
5 Valve Manifold-Pipe to Pipe	5VM-SS-8-R	12
5 Valve Manifold-Pipe to Flange	5VM-SS-8-T	13
5 Valve Manifold-Flange to Flange	5VM-SS-8-H	14
5 Valve Manifold Direct Mount	5VM-SS-8-DM	15
Model Coding & Ordering Information		16

# Valve Manifold

## Material of Construction

Sr No.	Part	Qty.	Material
1	Body	1	A479-316 / A-105
2	Gland Body	1	A479-316 / A-105
3	Gland Retainer	1	A479-316 / A-105
4	Washer	1	A479-316 / A-105
5	Packing	1	PTFE / Graphoil
6	Packing Washer	1	A276-316 / A-105
7	Spindle	1	A276-316
8	Lock Nut	1	A479-316 / A-105
9	Grub Screw	1	Steel
10	Handle	1	A276-304 / A-105
11	Lock Pin	1	A479-316 / A-105
12	Dust Cap	1	Plastic LD.
13	Vee Tip / Ball Tip	1	17-4 PH

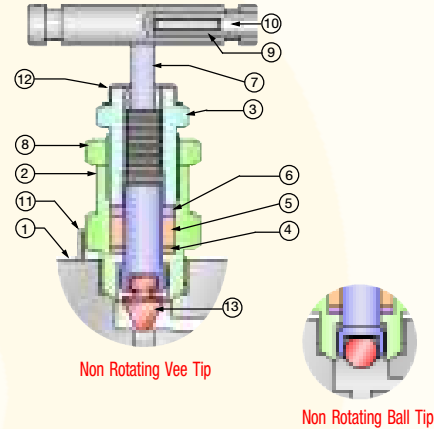

## Features/Benefits

Forged one piece body construction (no welding)

- For High strength.

Non Rotating Vee / Ball tip design

- which forms a bearing joint with the stem eliminates rotation between plug & seat at closure. This prevents scoring and galling up the valve seat and ensure long life in repetitive shut off service.

Safety Bonnet Lock

- Prevents accidental disassembly.

Stem thread Rolled & Hard Plated

- Provides additional strength & maximum service life.

Mirror Finish Stem, burnished to a 16RMS

- Extends packing life and smoothens stem operation.

Adjustable Packing Below Stem threads

- Prevents stem lubrication washout and isolates threads from process contamination.

Safety Back Seating

- Provides secondary stem seal in full open position, prevents stem blowout.

Stainless Steel Handle

- For proper actuation.

Body to Bonnet seal

- Metal to Metal constant compression, Isolates bonnet threads from system fluids and eliminates possible tensile.

Dust Cap

- Prevents contamination and lubricant washout out of bonnet assembly

## Pressure v/s. Temperature

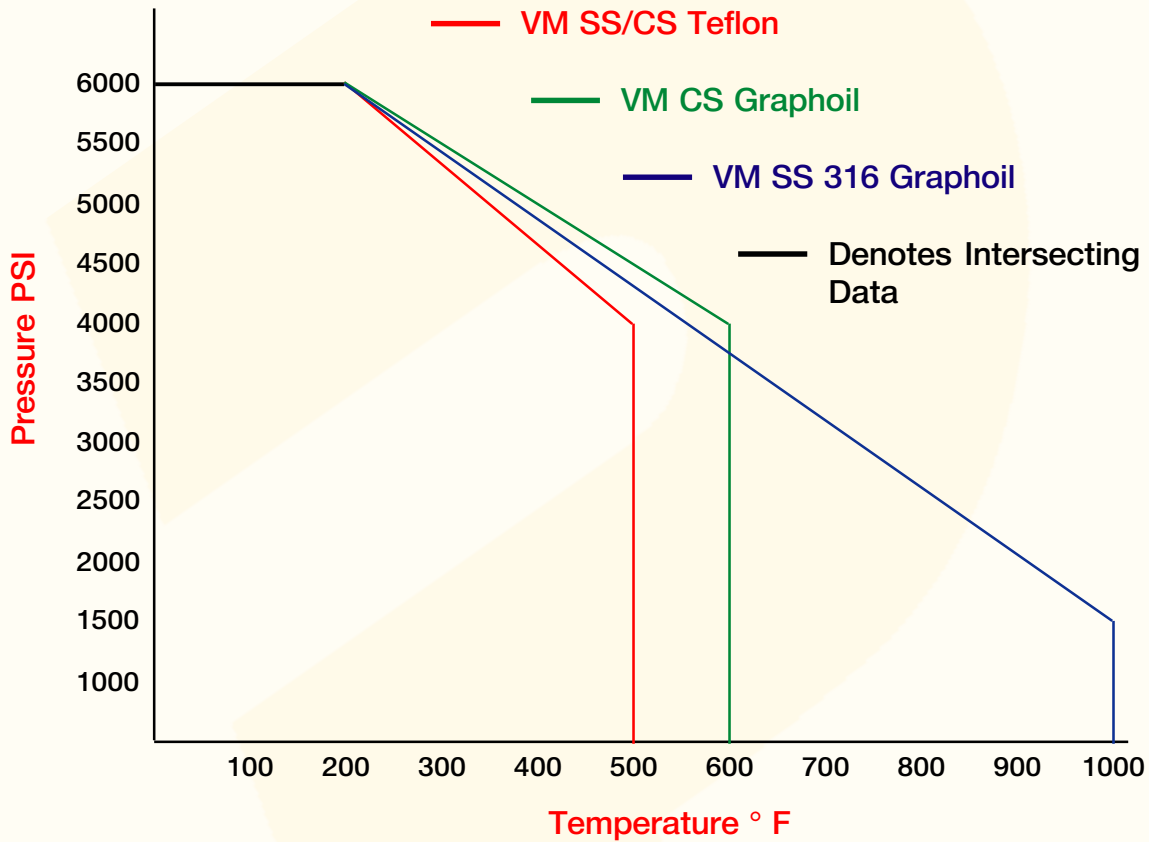

### Pressure Rating:-

Temp.	C.S.	S.S.	Orifice	Cv
Room	6000 PSI	6000 PSI		
500°F	4000 PSI	4000 PSI	4.8 mm	0.52 Max
1000°F	1500 PSI	1500 PSI		

### Manifold Selection:-

Pressure and temperature rating are selected from ANSI B16.34 for Standard class valves based on ANSI B16-Class 2500. Optional sour gas service confirms to NACE STD MR-01-75.

### Testing:

Each valve is tested with nitrogen gas at 1000 psi for seat and packing leakage with a maximum allowable leak rate of 0.1 sec/min.

Hydro test performed with pure water at 1 and 1/2 times of working pressure.

Other tests like vibration, temperatures, helium etc are available upon requests.

# Valve Manifold

## 2 Valve Manifold-Pipe to Pipe

**PANAM** 2 Valve Manifold Pipe to Pipe design for separate mounting, connecting system impulse lines and transmitters, having simple two valve configuration, which allows for easy block, bleed and calibration of a static pressure transmitter or gauge.

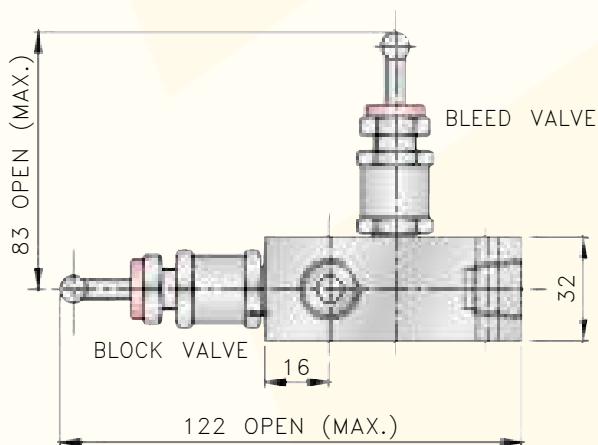

**View "BB"**

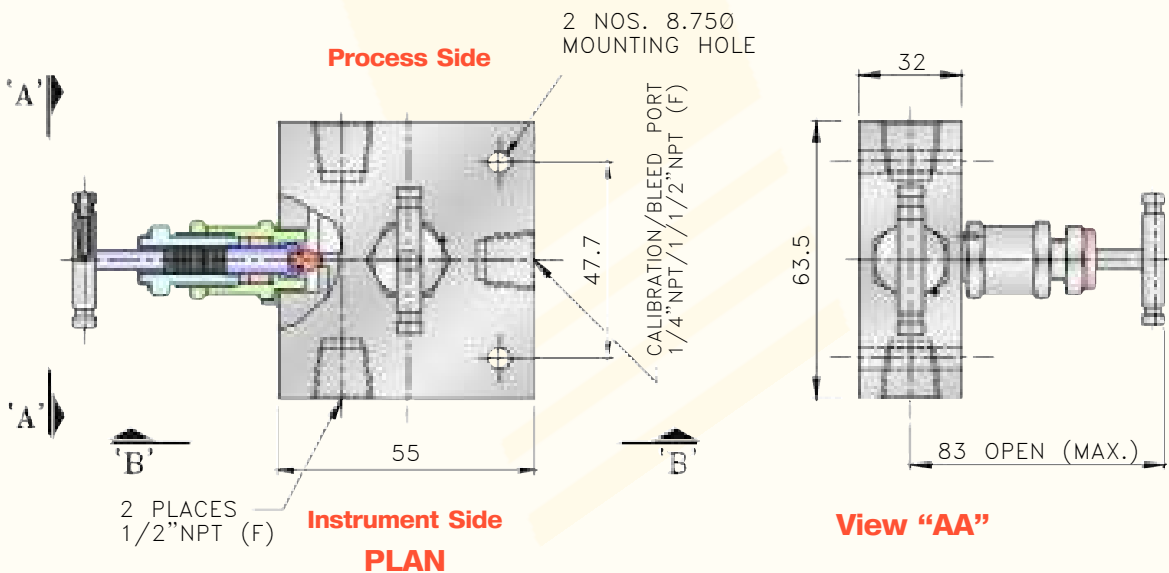
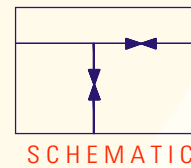

**View "AA"**

## 2 Valve Manifold-Pipe to Flange

**PANAM** 2 Valve Manifold Pipe to Flange design for separate mounting, connecting system impulse lines and transmitters, having simple two valve configuration which allows for easy block, bleed and calibration of static pressure transmitter or gauge.

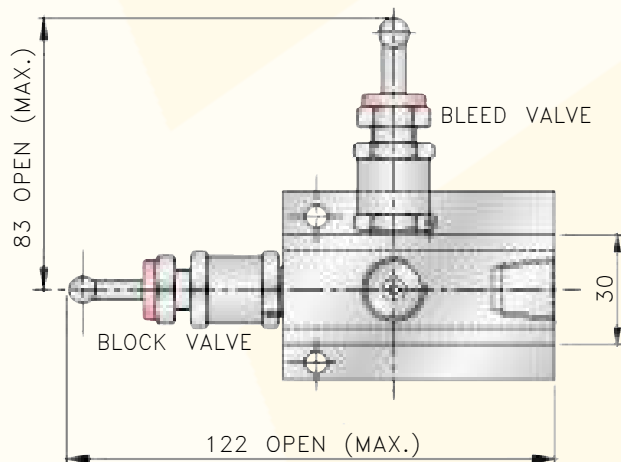

**View "BB"**

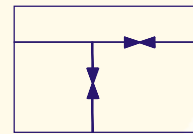

**SCHEMATIC**

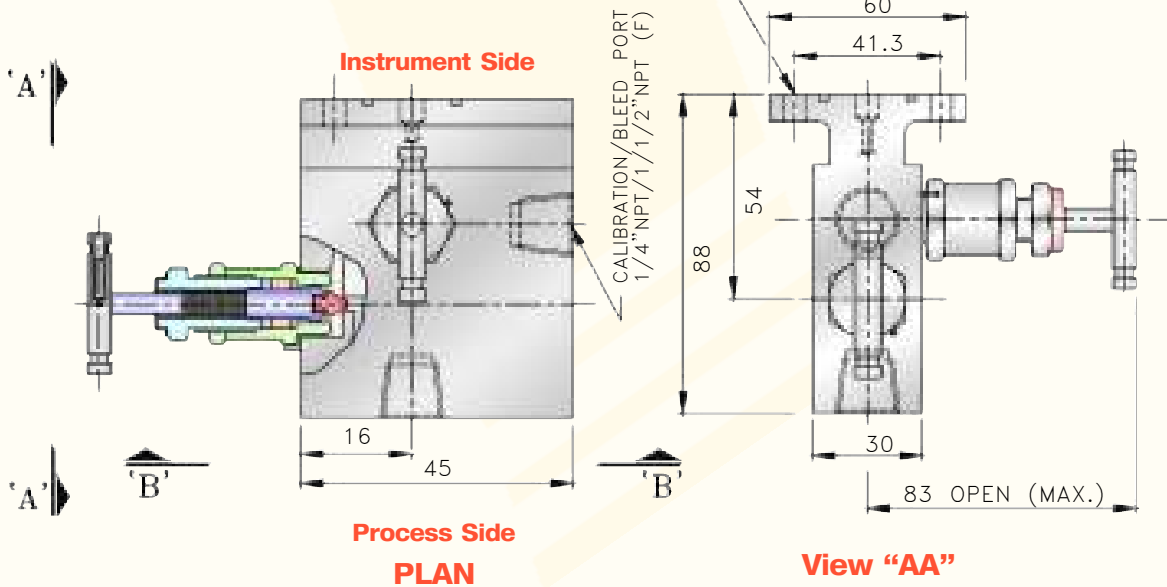

**Process Side PLAN**

**View "AA"**

# Valve Manifold

## 2 Valve Manifold-Flange to Flange

**PANAM** 2 Valve Manifold Flange to Flange design for separate mounting, connecting system impulse lines and transmitters, having simple two valve configuration which allows for easy block, bleed and calibration of static pressure transmitter or gauge.

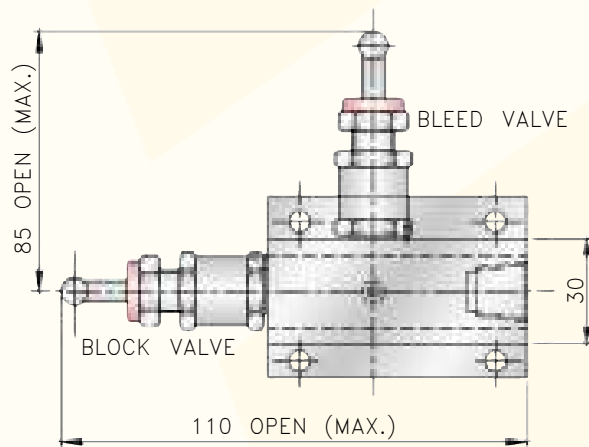
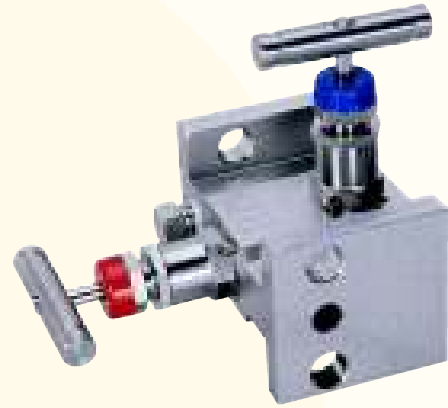

**View "BB"**

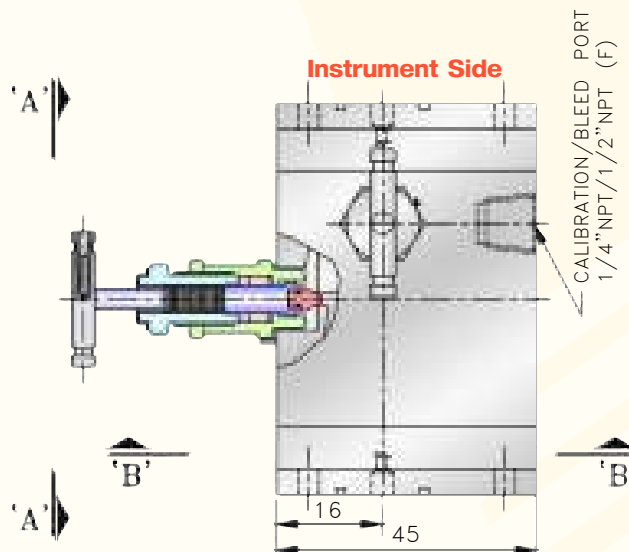
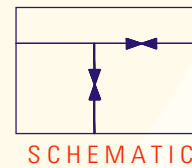

**Process Side  
PLAN**

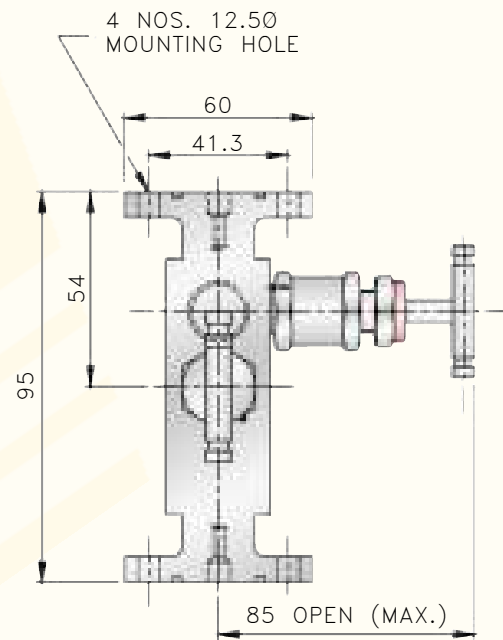

**View "AA"**



## 2 Valve Manifold-Remote Mount

**PANAM** 2 Valve Manifold-Remote Mount Flange to Flange design for separate mounting, connecting system, impulse lines and transmitters, having simple two valve configuration which allows for easy block, bleed and calibration of a static pressure transmitter or gauge.

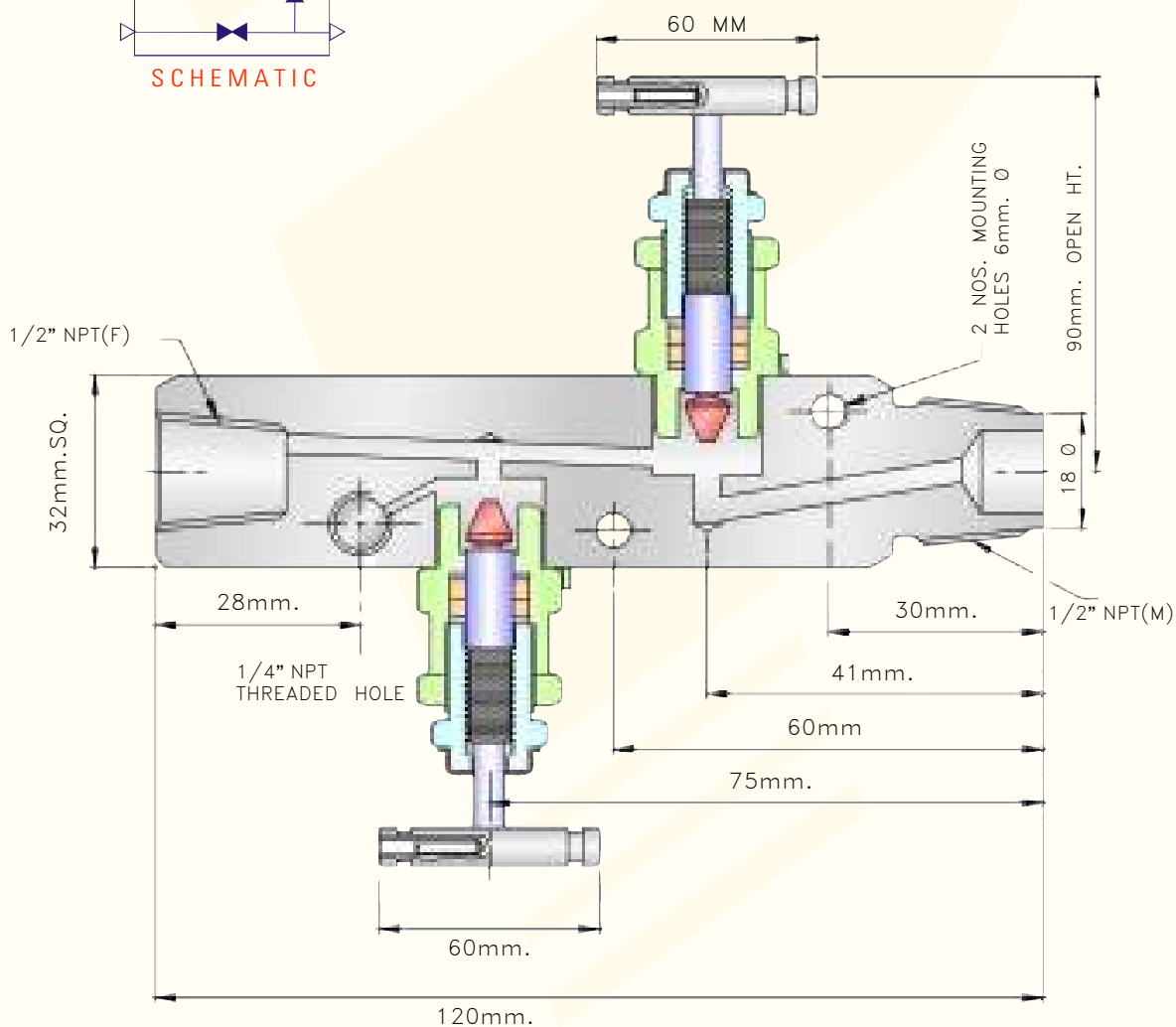
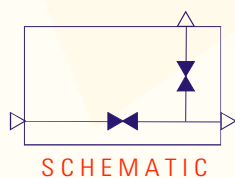

# Valve Manifold

## 2 Valve Manifold-Direct Mount

**PANAM** 2 Valve Manifold Pipe to Flange design for direct mounting, connecting system impulse lines and transmitters, having simple two valve configuration which allows for easy block, bleed and calibration of a static pressure transmitter or gauge.

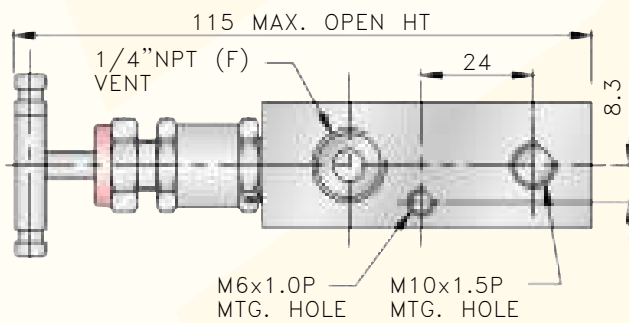

View "BB"

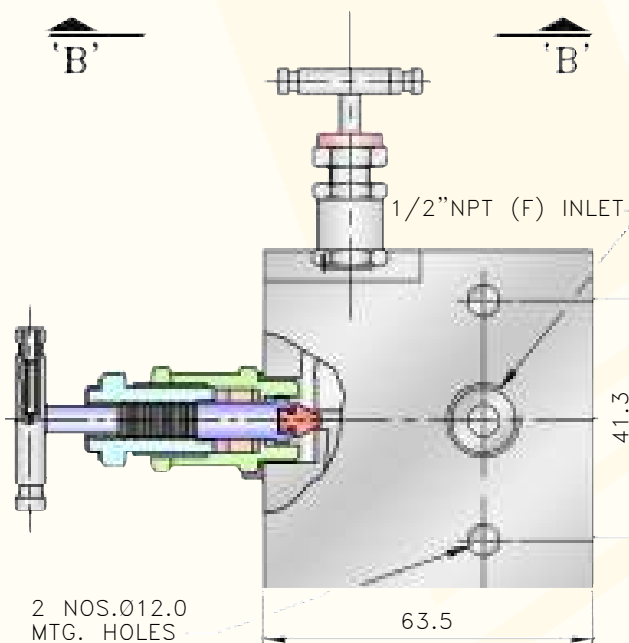
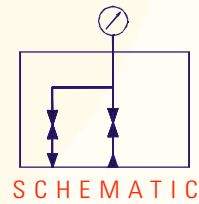

View "AA"

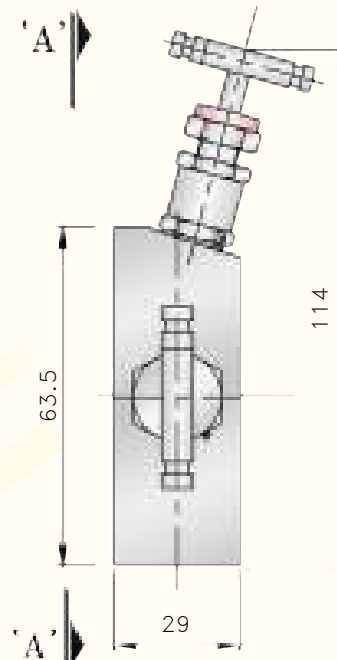

Side View

## 3 Valve Manifold-Pipe to pipe

**PANAM** 3 Valve Manifold Pipe to Pipe design for connecting system impulse lines and transmitters. This valve consist of 1/2" NPT Female connections on 54 mm. (2-1/8") centres and one equalizer valve and two block valve.

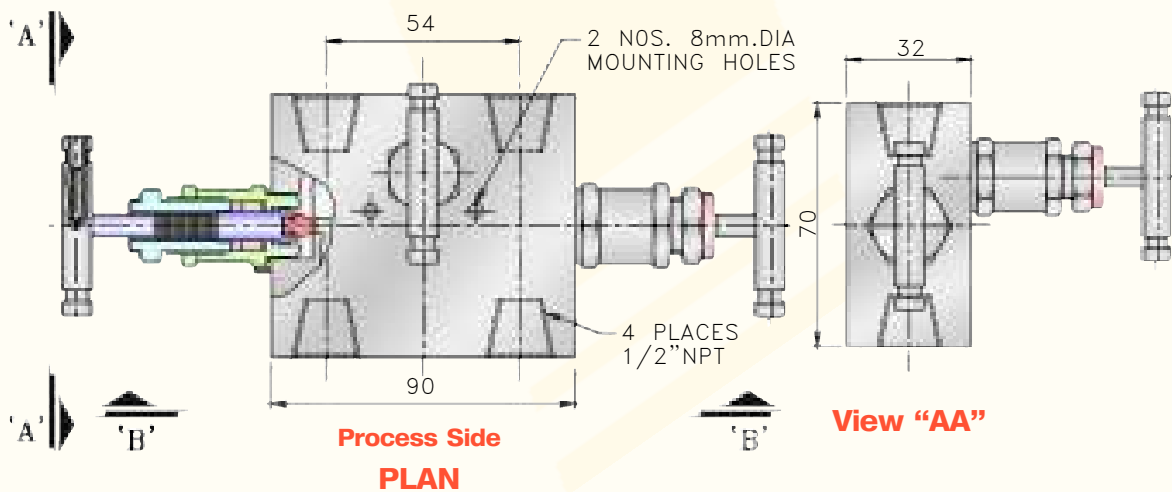
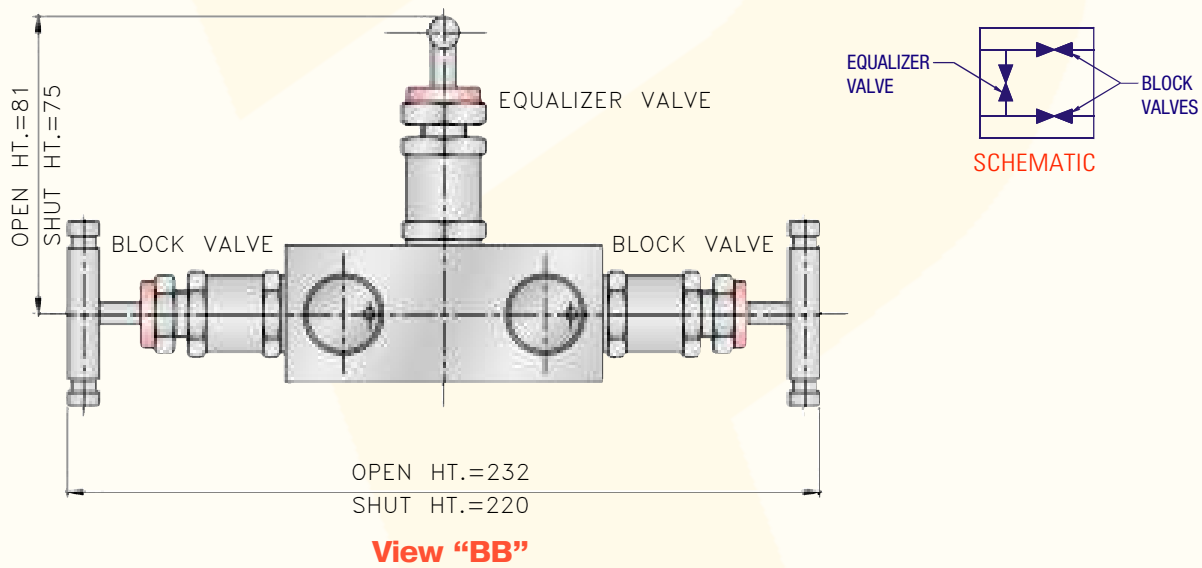

# Valve Manifold

## 3 Valve Manifold-Pipe to Flange

**PANAM** 3 Valve Manifold Pipe to Flange design for connecting system impulse lines and transmitters. This valve consist of 1/2" NPT Female connections on 54 mm. (2-1/8") centres and of one equalizer valve and two block valves. 1/4" NPT purge connections (2) optional.

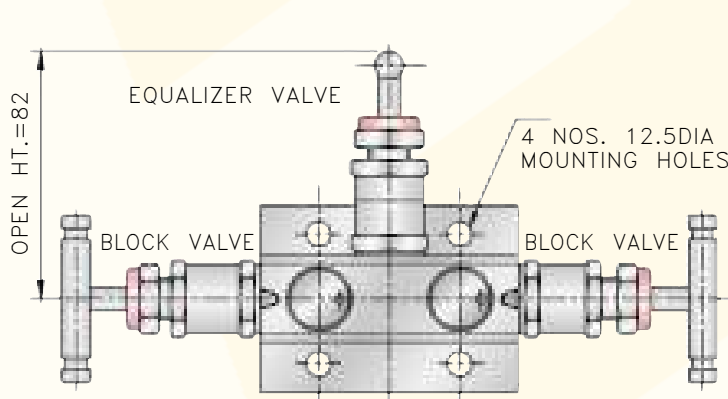

**View "BB"**

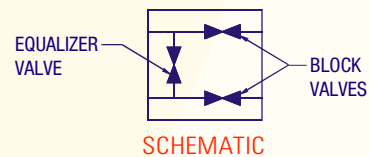

**Instrument Side**

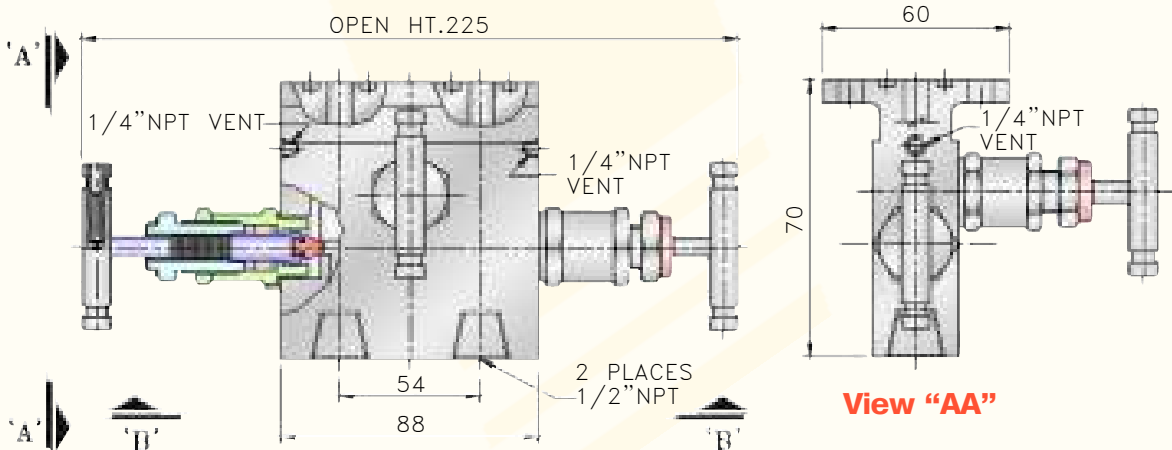

**Process Side  
PLAN**

## 3 Valve Manifold-Flange to Flange

**PANAM** 3 Valve Manifold Flange to Flange design for connecting system impulse lines and transmitters. This valve consists of Flange to Flange connections on 54 mm. (2-1/8") centres and one equalizer valve and two block valves.

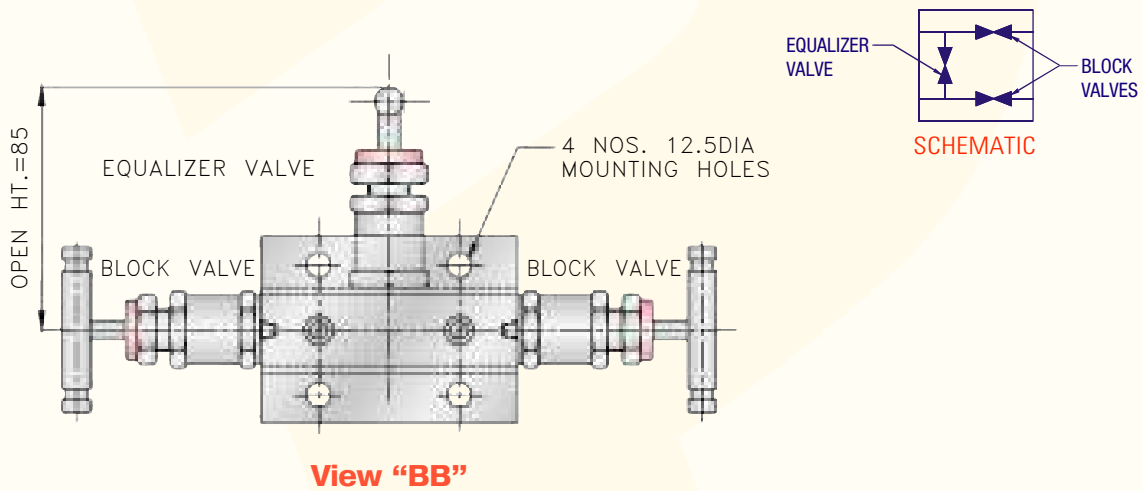

**Instrument Side**

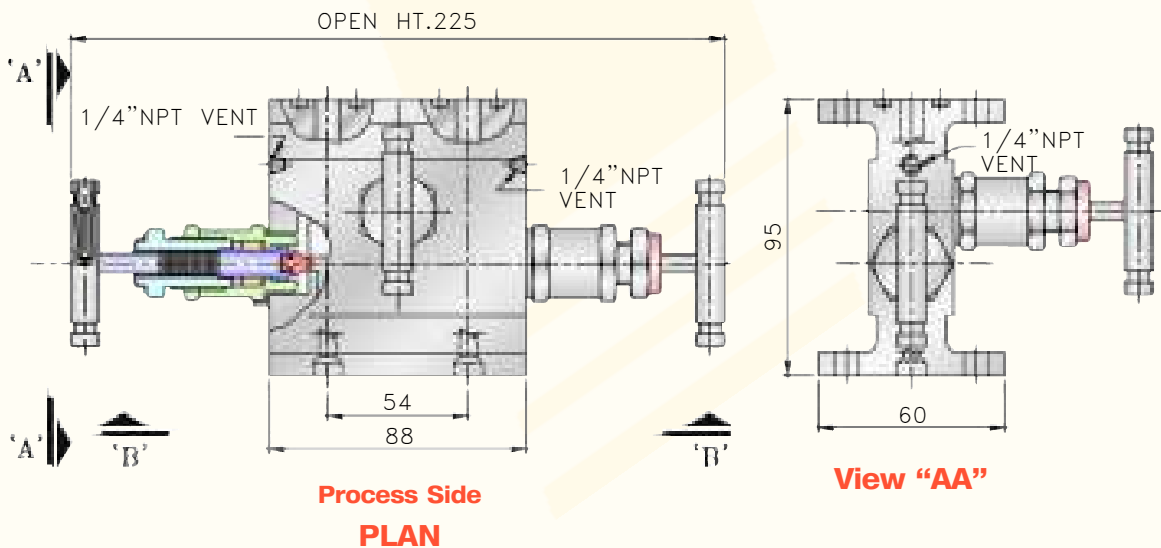

# Valve Manifold

## 3 Valve Manifold-Direct Mount

**PANAM** 3 Valve Manifold Pipe to Flange, base mount connection design for connecting system impulse lines and transmitters. This valve consists of 1/2" NPT Female connections on 54 mm. (2-1/8") centres and one equalizer valve and two block valves.

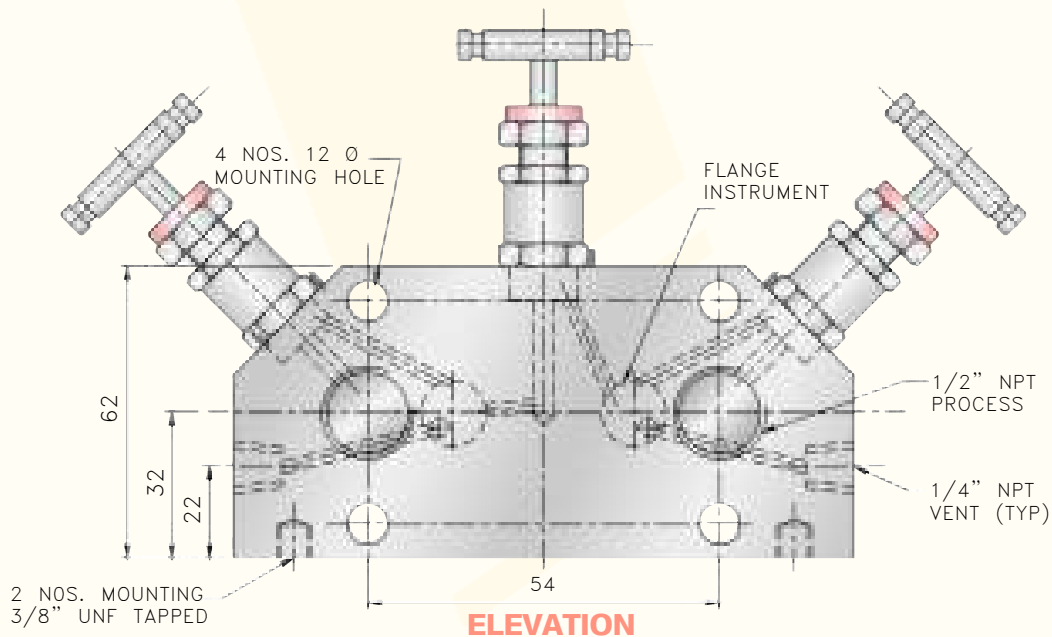
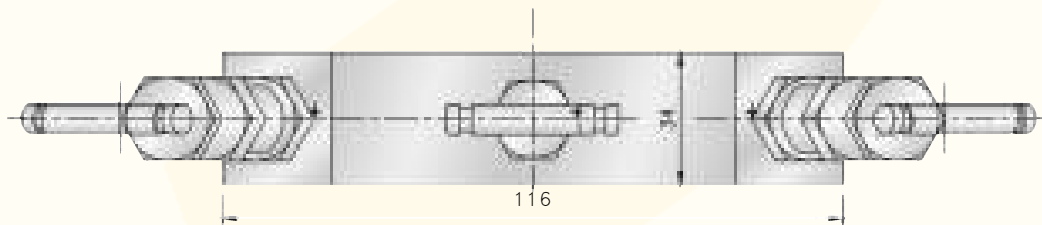
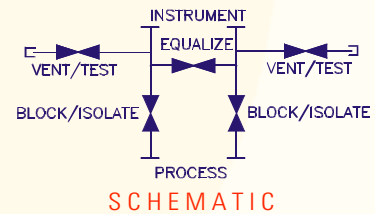
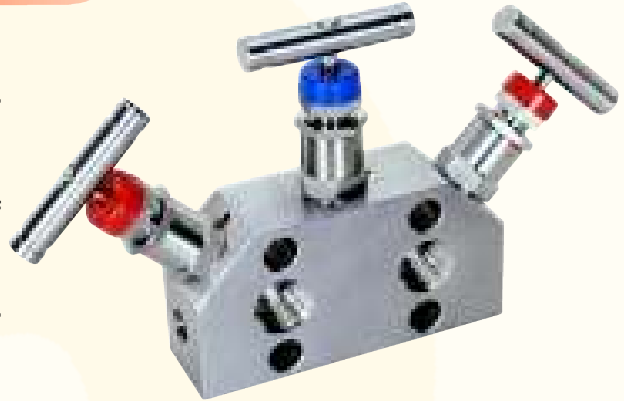

## 5 Valve Manifold-Pipe to pipe

**PANAM** 5 Valve Manifold Pipe to Pipe design for connecting system impulse lines and transmitters. This valve consist of 1/2" NPT Female connections on 54 mm. (2-1/8") centres to suit the inlet connection. This Valve provides two instrument isolating valves, Two equalizer valves and One bleed valve. (For Testing).

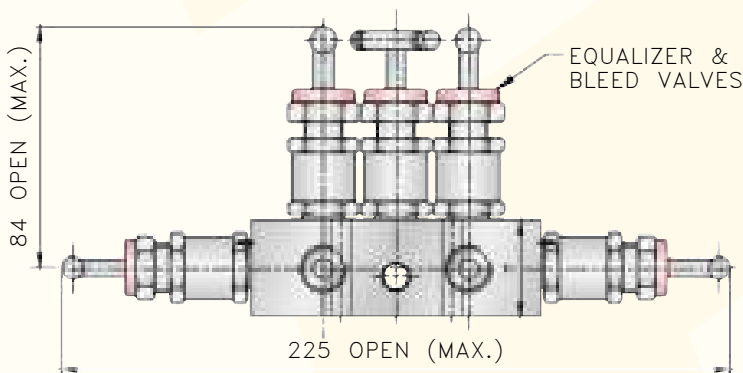
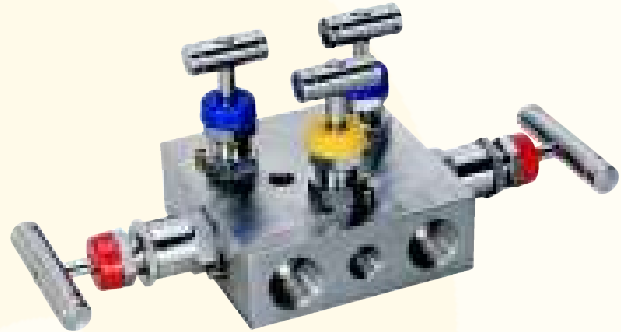

**View "BB"**

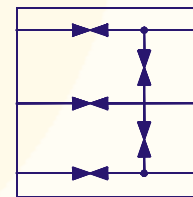

**SCHEMATIC**

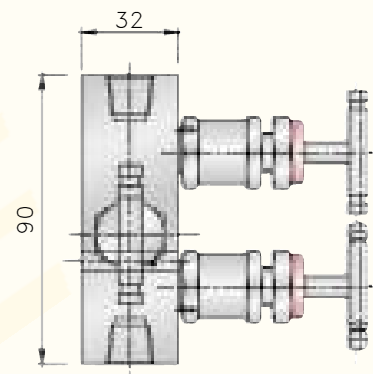
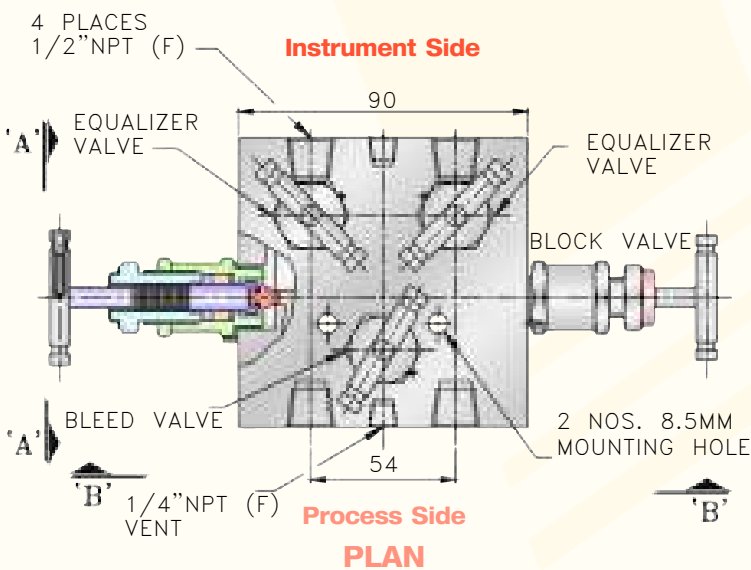

**View "AA"**

# Valve Manifold

## 5 Valve Manifold-Pipe to Flange

**PANAM** 5 Valve Manifold Pipe to Flange design for connecting system impulse lines and transmitters. This valve consist Pipe to Flange connections with Teflon/ Viton O-Ring packing on 54 mm. (2-1/8") centres to suit the inlet connection. This Valve provides two instrument isolating valves, Two equalizer valves and One bleed valve. (For Testing).

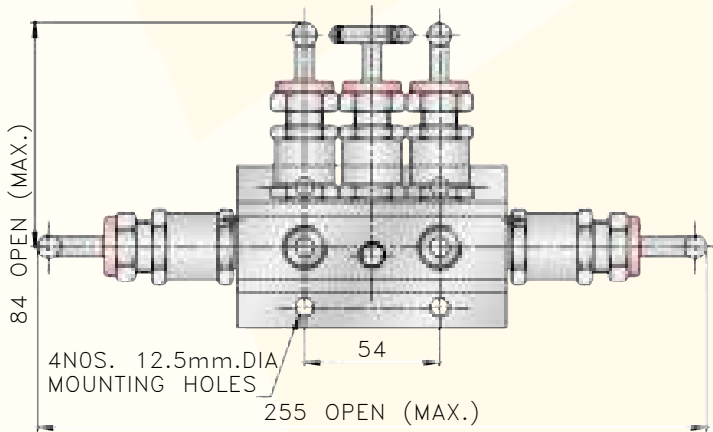
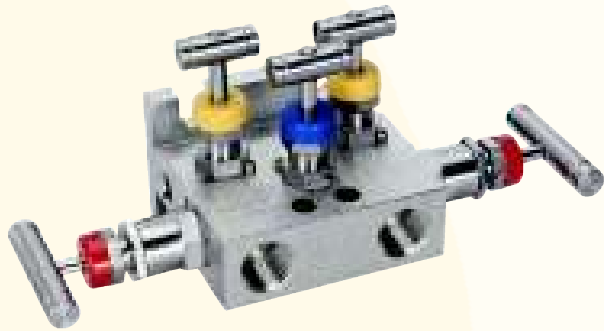

**View "BB"**

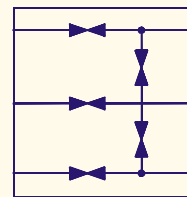

**SCHEMATIC**

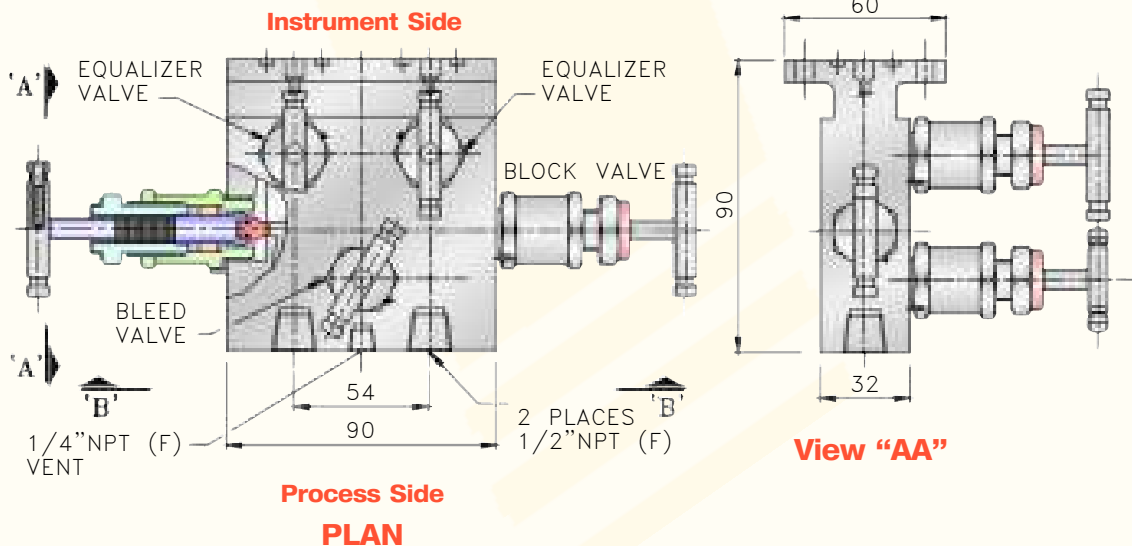

**View "AA"**



## 5 Valve Manifold-Flange to Flange

**PANAM** 5 Valve Manifold Flange to Flange design for connecting system impulse lines and transmitters. This valve consist two Flange connections with Teflon/Viton O-Ring packing on 54 mm. (2-1/8") centres to suit the inlet connection. This Valve provides two instrument isolating valves, Two equalizer valves and One bleed valve. (For Testing).

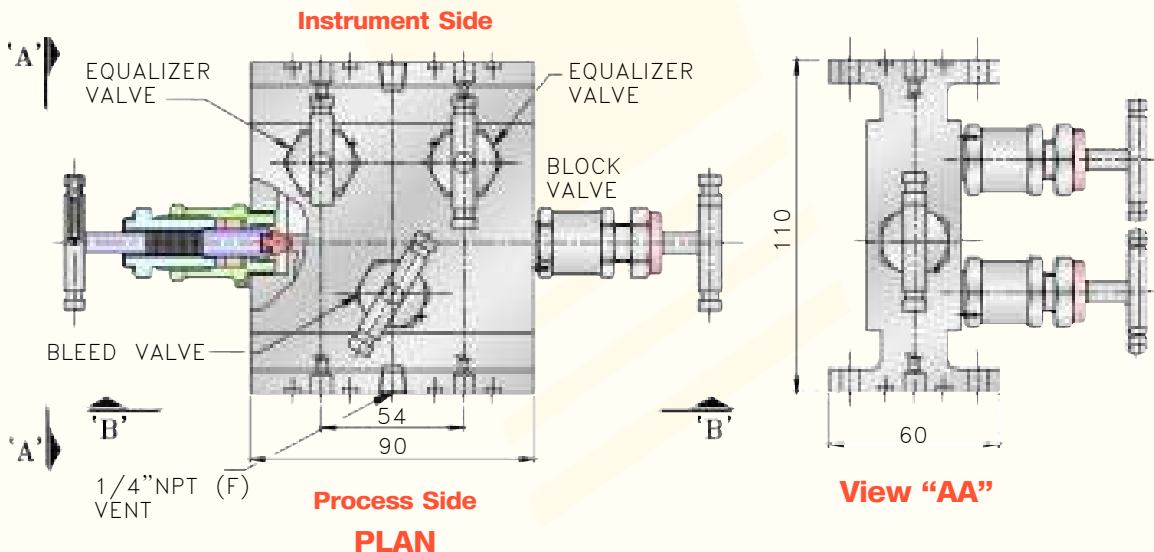
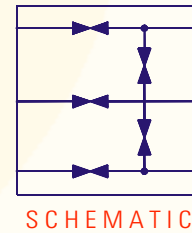
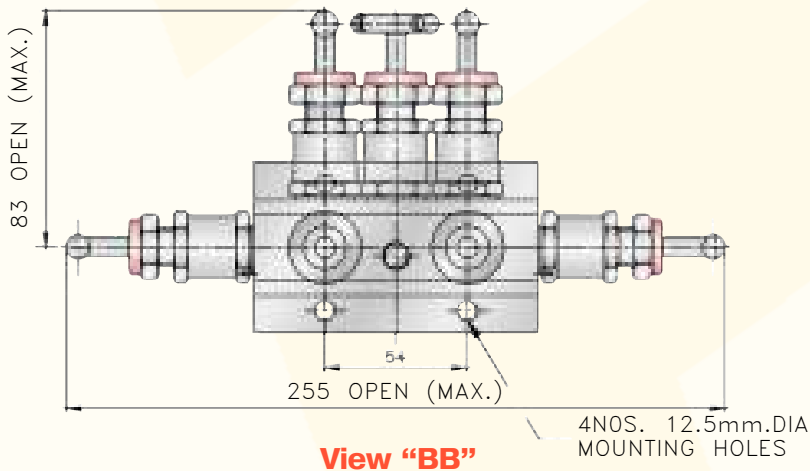
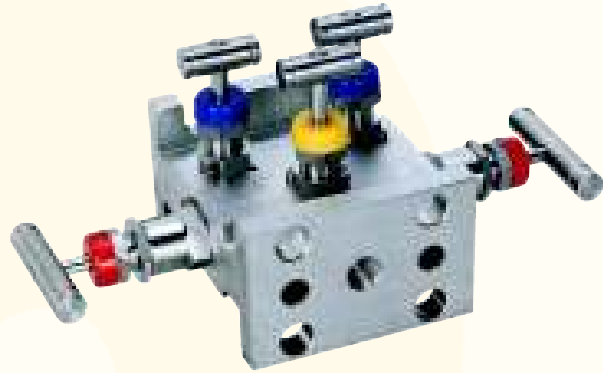

# Valve Manifold

## 5 Valve Manifold-Direct Mount

**PANAM** 5 Valve Manifold Integral mounting connection design for connecting system impulse lines and transmitters. This valve consist to 1/2" NPT Female connections on 54mm (2-1/8") centres and of Two equalizer valves, Two block valves and One vent valve.

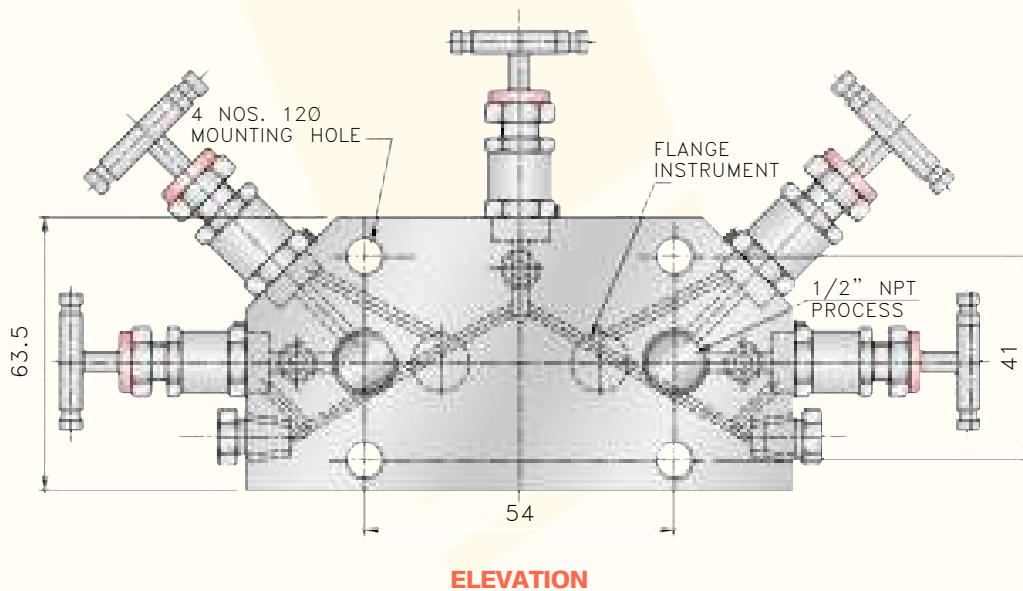
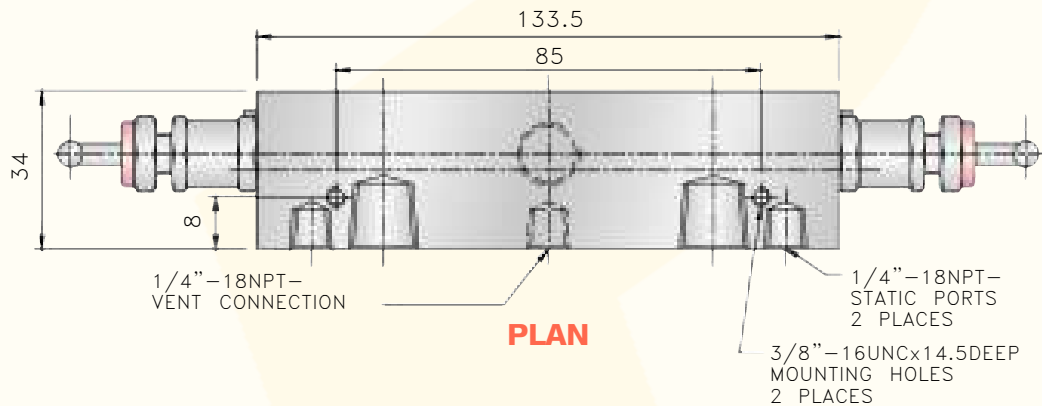
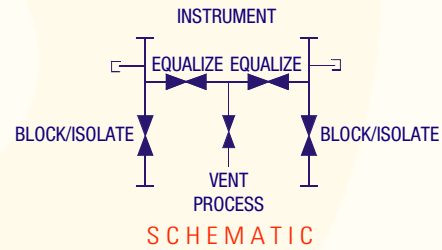
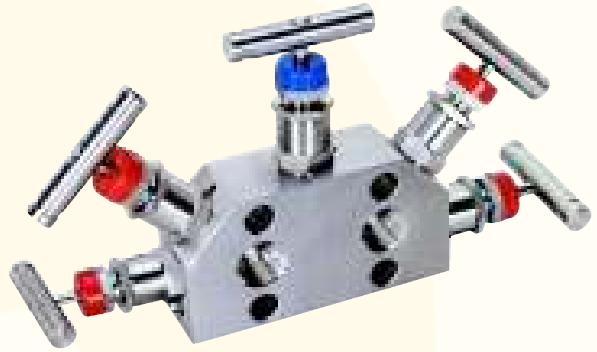

## Model Coding & Ordering Information

	2 -	VM -	SS -	8 -	R
<b>No of Valves</b>					
2 Valves					
3 Valves					
5 Valves					
<b>Valve Manifold</b>					
<b>Material</b>					
SS - 316 SS					
CS - Carbon Steel					
M - Monel					
<b>Process Connection</b>					
8 - 1/2" NPT					
4 - 1/4" NPT					
<b>Mounting</b>					
R - Pipe to Pipe					
T - Pipe to Flange					
H - Flange to Flange					
<b>Optional</b>					
SG-Sour Gas Service Confirms to NACE MR 01-75					
G - Graphoil Packing for High Temperature					



## ***PANAM ENGINEERS***

**AN ISO 9001:2000 COMPANY**

---

412, Hingkee Building, 4th Floor, 155/157 Samuel Street, Mumbai-400 009. INDIA.  
Tel.: 91-22-2345 4582/4425 • Fax: 91-22-2347 6619.  
E-mail: [sales@panamengineers.com](mailto:sales@panamengineers.com) • Website: [www.panamengineers.com](http://www.panamengineers.com)