

PANAM

GAUGE ROOT VALVES



Catlogue No. GRV-1
June 2003.

Gauge Root Valves

PANAM Gauge root valves are used for safe installation in pressure switches, gauges and differential pressure transmitters, suitable for Block and Bleed assemblies to test pressure source required in sampling line or purge valve.

Features:- 316 S.S. construction for corrosion resistance. Non rotating vee or ball tip. Extended body for insulation clearance. Scheduled 160 or heavier pipe valve inlet for strength. Optional graphoil packing available for high temperatures with all ball/vee tip design which forms a bearing joint with the stem which eliminates rotation between ball/vee tip & seat at closure. This prevents scoring and galling up the valve seat and ensures long life in repetitive shut off service.

Material of Construction

Sr No.	Part	Qty.	Material
1	Body	1	A-479-316 / A-105
2	Stem	1	A-479-316 / A-105
3	Spacer	2	A-479-316 / A-105
4	Gland Body	1	A-479-316 / A-105
5	Gland Packing	2	Teflon / Graphoil
6	Gland Lock Nut	1	A-479-316 / A-105
7	Gland Retainer	1	A-479-316 / A-105
8	Dust Cap	1	Plastic / LD
9	Grub Screw	1	Steel Plated
10	Washer	1	A-479-316 / A-105
11	Handle	1	Stainless Steel
12	Vee / Ball Tip	1	Titanium/17-4PH

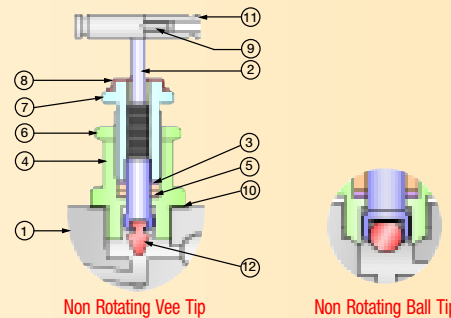

Dimensions

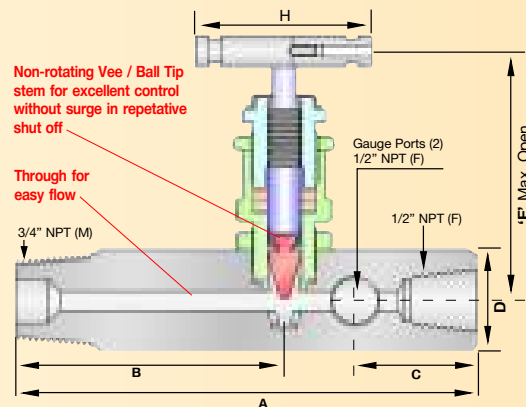
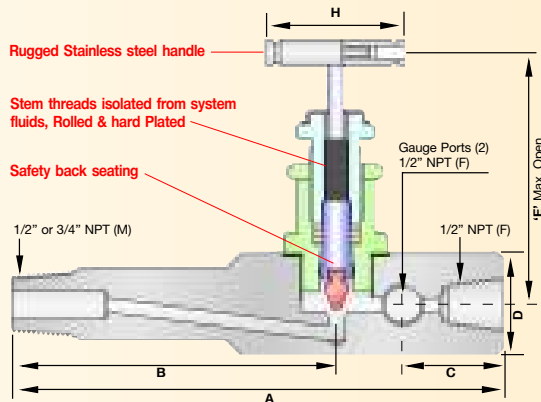

Body	Orifice mm.	Connecting Size		Dimensions					
		Inlet	Outlet	A	B	C	D	E	H
Short	5	1/2" NPT	1/2" NPT	137	76	38	32 SQ.	90	64
Lagging Extension		3/4" NPT	1/2" NPT	184	123	38	32 SQ.	90	64

MAT.	SEAT	TEMP. RATING	PR. RATING @ 100° F (38°C)
S. S. 316	V-Stem	-65° F to 450° F	6000 PSI (41,300 Kpa)
	Rising Plug	(-54° F to 232° C)	

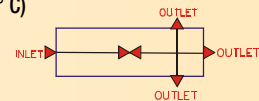

Testing:

Each valve is tested with nitrogen gas at 1000 psi for seat and packing leakage with a maximum allowable leak rate of 0.1 sec/min.

Hydro test performed with pure water at 1 and 1/2 times of working pressure.

Other tests like vibration, temperatures, helium etc are available upon requests.



PANAM ENGINEERS
AN ISO 9001:2000 COMPANY

412, Hingkee Building, 4th Floor, 155/157 Samuel Street, Mumbai-400 009. INDIA • Tel.: 91-22-2345 4582/4425 • Fax: 91-22-2347 6619.

E-mail: sales@panamengineers.com • Website: www.panamengineers.com